

---

Formula Renault 2.0 Northern European Cup  
DMSB Genehmigungs-Nummer: 505/14

## Bulletin N° 06, 2014

### EuroCup Bulletins

We add to the Northern European Cup Formula Renault 2.0 regulations the following Bulletin (attached):

N°02 (BT\_2014\_FR20\_2\_UK/ Carbon floor extension repair)

All official changes, being sporting, technical or technical rules or in attachments, will be posted on [www.necup.com](http://www.necup.com) throughout the 2014 season.

Best regards

Ralph Weishaupt  
Renault Deutschland AG

Freigabe durch den DMSB  
*Approved by the ASN*

Datum, 28.04.2014  
*date, 2014-04-28*

  
D. Fürst



REFERENCE	BT_2014_FR20_2_UK
DATE	April 24th, 2014
SUBJECT	Carbon floor extension repair
PART	Carbon floor, carbon floor extension

**Carbon floor extension repair**

It is allowed to use carbon floors (n.1 & 2) with repaired front floor extension areas (areas **A**) with no change in weight and dimension.

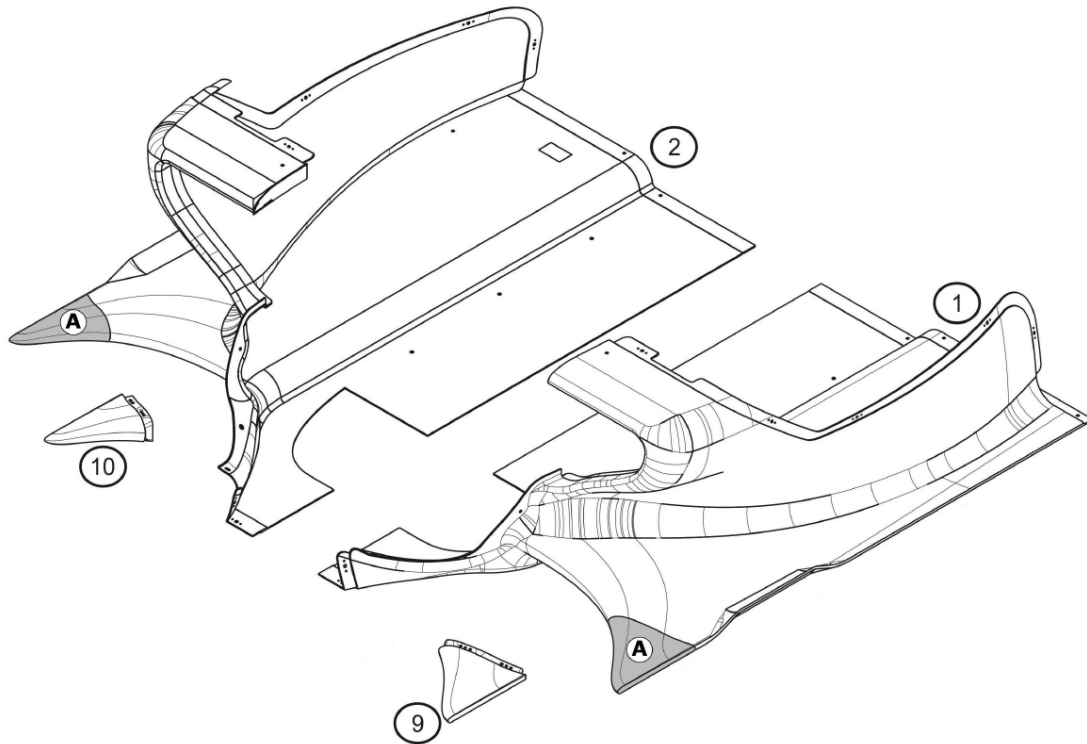

Superficial repairs applied to the removable front floor extensions (n.9&10) are tolerated.

It is allowed to bond the removable extensions to the floor without modifying the extensions.